

BRITE III Remote Control Device

Installation Manual

96A0429

Retain for future use.

Rev. D, 8/12/11



Compliance with Standards

FAA: Approved for use with SMGCS systems. This includes both Stop Bar and Runway Guard Light control/monitoring according to AC 150/5340-30 (Current Edition); manufactured to AC 120-57 (Current Edition).

ICAO: Complies with CAT I/II/III ICAO lamp supervision requirements. Supports A-SMGCS for enhanced aircraft guidance in all weather conditions to prevent aircraft collisions and runway incursions.

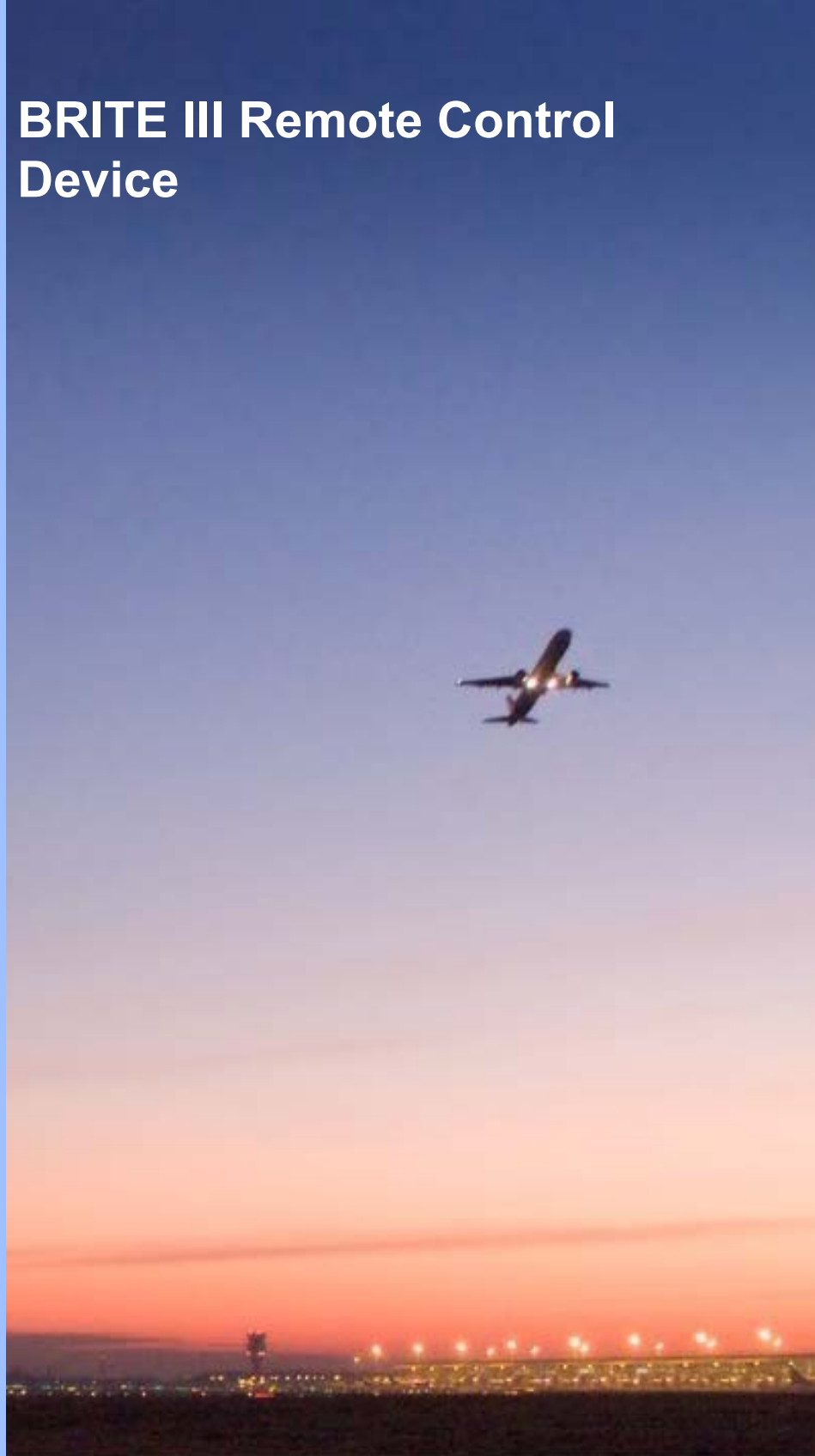

Disclaimer

This manual could contain technical inaccuracies or typographical errors. ADB Airfield Solutions reserves the right to revise this manual from time to time in the contents thereof without obligation of ADB Airfield Solutions to notify any person of such revision or change.

Details and values given in this manual have been compiled with care. They are not binding, however, and ADB Airfield Solutions disclaims any liability for damages or detriments suffered as a result of reliance on the information given herein or the use of products, processes or equipment to which this manual refers. No warranty is made that the use of the information or of the products, processes or equipment to which this manual refers will not infringe any third party's patents or rights.

Warranties

Products of ADB Airfield Solutions manufacturer are guaranteed against mechanical, electrical, and physical defects (excluding lamps) for a period of one year from the date of installation or a maximum of 18 months from date of shipment and are guaranteed to be merchantable and fit for the ordinary purposes for which such products are made.

ADB Airfield Solutions will correct by repair or replacement, at its option, equipment or parts which fail because of mechanical, electrical or physical defects, provided that the goods have been properly handled and stored prior to installation, properly installed and properly operated after installation, and provided further that Buyer gives ADB Airfield Solutions written notice of such defects after delivery of the goods to Buyer. Refer to the Safety section for more information on Material Handling Precautions and Storage precautions that must be followed.

ADB Airfield Solutions reserves the right to examine goods upon which a claim is made. Said goods must be presented in the same condition as when the defect therein was discovered. ADB Airfield Solutions further reserves the right to require the return of such goods to establish any claim.

ADB Airfield Solutions' obligation under this guarantee is limited to making repair or replacement within a reasonable time after receipt of such written notice and does not include any other costs such as the cost of removal of defective part, installation of repaired product, labor or consequential damages of any kind, the exclusive remedy being to require such new parts to be furnished.

ADB Airfield Solutions' liability under no circumstances will exceed the contract price of goods claimed to be defective. Any returns under this guarantee are to be on a transportation charges prepaid basis. For products not manufactured by, but sold by ADB Airfield Solutions, warranty is limited to that extended by the original manufacturer.

This is ADB Airfield Solutions' sole guarantee and warranty with respect to the goods; there are no express warranties or warranties of fitness for any particular purpose or any implied warranties of fitness for any particular purpose or any implied warranties other than those made expressly herein. All such warranties being expressly disclaimed.

Trademarks

General notice: other product names used here are for identification purposes only and may be trademarks of their respective companies.

Proprietary Information

This information carrier contains proprietary information, which shall not be used for other purposes than those for which it has been released, nor be reproduced or disclosed to third parties without the prior written consent of ADB Airfield Solutions.

No part of this publication may be reproduced, stored in a retrieval system, or transmitted in any form or by any means, mechanical, photocopy, recording, or otherwise, without the prior written permission of ADB Airfield Solutions. No patent liability is assumed with respect to the use of the information contained herein. Neither is any liability assumed for damages resulting from the use of the information contained herein.

ADB Airfield Solutions shall not be liable to the purchaser of this product or third parties for damages, losses, costs, or expenses incurred by purchaser or third parties as a result of accident, misuse, or abuse of this product or unauthorized modifications, repairs, or alterations to this product. ADB Airfield Solutions shall not be liable against any damages arising from the use of any options or parts other than those designated as approved products.

Copyright © 2010 by ADB Airfield Solutions. All rights reserved.

a.0 Terms and Acronyms

a.1 Terms

General Aviation Terms and Acronyms that you may encounter using our manuals.

ALCS	Acronym for Airfield Lighting Computer System. An ALCS incorporates many components that are used to control and monitor an airport's entire airfield lighting system. The ALCS may include Touch Screens for lighting control, Maintenance Center(s) for data viewing and archiving, Electrical Lighting equipment for CCR control and monitoring.
CCR	Abbreviation for Constant Current Regulator. The CCRs are located within the Airfield Lighting Vault or substation. They produce a constant current output to the airfield series circuit that light the airfield lighting fixtures.
BRITE™	ADB Airfield Solutions' trademarked abbreviation for Bi-directional Series Transceiver which is a term that describes the technology used to transmit and receive data across airfield lighting series circuit cabling.
Remote	Unit installed in the airfield (normally in pull-pits or base cans) which provides control and monitoring of individual or blocks of light fixtures. Each Remote has its own unique address for control and monitoring data communication to the Master.
Master	Unit installed within the lighting vault that provides the means for data communication on the airfield series circuit cables. The Master is connected in parallel (across) to the output of the CCR. Each series circuit that contains Remotes must also have a Master installed at the CCR.
MWD	Abbreviation of Microwave Detector. Microwave detectors are installed in pre-designated locations on the airfield. The MWD also has its own unique address for control and monitoring purposes. A MWD is used to detect movement within an established detection zone and communicate the status back to the Master.
Control Panel	This term is used to reference the device used to control and monitor the controllable stopbars and the associated lighting equipment. The control panel could be either an L-821 style pushbutton panel or a Touchscreen style control panel. The control panel is located in the Air Traffic Control Tower cab.
SMGCS	Acronym which means Surface Movement Guidance and Control System. SMGCS is an organized system created to improve and enhance low visibility operations.
VSP	Acronym for Variable System Parameter. This term relates to a time value (in seconds) determined by the airport that is used in conjunction with the Stopbar control timing. In the event that the automatic Stopbar control or MWDs fail, the Stopbars are reset after the VSP value has expired.

TABLE OF CONTENTS

BRITE III Remote Control Device i

a.0: Terms and Acronyms III

a.1 :Terms iii

1.0: Safety 1

1.1 :To use this equipment: 1

 1.1.1 :Additional Reference Materials: 1

 1.1.2 :Qualified Personnel 1

 1.1.3 :Intended Use 1

 1.1.4 :Storage 1

 1.1.4.1 :Operation 2

 1.1.4.2 :Material Handling Precautions 2

 1.1.4.3 :Action in the Event of a System or Component Malfunction 2

 1.1.4.4 :Maintenance and Repair 2

 1.1.4.5 :Operation of Overloaded Regulators 2

2.0: BRITE III Remote 3

2.1 :Manual Introduction 3

 2.1.1 :How to work with the manual 3

 2.1.2 :Record of changes 3

 2.1.3 :Icons used in the manual 3

2.2 :BRITE Remote Introduction 4

 2.2.1 :General 4

 2.2.2 :Illustration 4

 2.2.3 :Checking the Device 5

 2.2.3.1 :Scope of Supply 5

 2.2.3.2 :Unpacking 5

 2.2.3.3 :Inspection 5

 2.2.3.4 :Storage 6

 2.2.4 :View of the device with connections 6

 2.2.5 :Construction 7

 2.2.5.1 :Block diagram 7

 2.2.6 :Theory of Operation 8

 2.2.6.1 :Architecture 8

2.3 :Installation 9

 2.3.1 :Installation in a Transformer Pit 9

 2.3.2 :Connection to the Series Transformer and the Light Fitting(s) 10

 2.3.3 :Earth Grounding 10

 2.3.4 :Safety Instructions 11

 2.3.5 :Replacing a BRITE Remote 11

2.4 :Modes of Operation of a BRITE Remote 13

 2.4.1 :Frequency Scan 13

 2.4.2 :Operating Mode 13

 2.4.2.1 :Self-test Mode 13

 2.4.3 :Switch Status of the Connected Lights 14

 2.4.4 :Switch Status under Special Circumstances 14

 2.4.4.1 :Power-up Mode 14

 2.4.4.2 :Fail-safe Mode 14

 2.4.4.3 :Delayed Start/Stop 14

 2.4.5 :Spreadsheet 14

 2.4.5.1 :A sample spreadsheet would contain: 15

2.5 :Technical Specifications 16

 2.5.1 :Order Codes 17

Table of Contents

Document Date (12/2010)

20

1.0 Safety

This section contains general safety instructions for installing and using ADB Airfield Solutions equipment. Some safety instructions may not apply to the equipment in this manual. Task- and equipment-specific warnings are included in other sections of this manual where appropriate.

1.1 To use this equipment:



WARNING

Read installation instructions in their entirety before starting installation.

- Refer to the FAA Advisory Circular AC 150/5340-26, Maintenance of Airport Visual Aids Facilities, for instructions on safety precautions.
- Observe all safety regulations. To avoid injuries, always disconnect power before making any wiring connections or touching any parts. Refer to FAA Advisory Circular AC 150/5340-26.
- Become familiar with the general safety instructions in this section of the manual before installing, operating, maintaining or repairing this equipment.
- Read and carefully follow the instructions throughout this manual for performing specific tasks and working with specific equipment.
- Make this manual available to personnel installing, operating, maintaining or repairing this equipment.
- Follow all applicable safety procedures required by your company, industry standards and government or other regulatory agencies.
- Install all electrical connections to local code.
- Use only electrical wire of sufficient gauge and insulation to handle the rated current demand. All wiring must meet local codes.
- Route electrical wiring along a protected path. Make sure they will not be damaged by moving equipment.
- Protect components from damage, wear, and harsh environment conditions.
- Allow ample room for maintenance, panel accessibility, and cover removal.
- Protect components from damage, wear, and harsh environment conditions.
- Allow ample room for maintenance, panel accessibility, and cover removal.
- Protect equipment with safety devices as specified by applicable safety regulations.
- If safety devices must be removed for installation, install them immediately after the work is completed and check them for proper functioning prior to returning power to the circuit.

1.1.1 Additional Reference Materials:

- NFPA 70B, Electrical Equipment Maintenance.
- NFPA 70E, Electrical Safety Requirements for Employee Workplaces.
- ANSI/NFPA 79, Electrical Standards for Metalworking Machine Tools.
- OSHA 29 CFR, Part 1910, Occupational Health and Safety Standards.
- National and local electrical codes and standards.

1.1.2 Qualified Personnel

The term **qualified personnel** is defined here as individuals who thoroughly understand the equipment and its safe operation, maintenance and repair. Qualified personnel are physically capable of performing the required tasks, familiar with all relevant safety rules and regulations and have been trained to safely install, operate, maintain and repair the equipment. It is the responsibility of the company operating this equipment to ensure that its personnel meet these requirements.

Always use required personal protective equipment (PPE) and follow safe electrical work practices.

1.1.3 Intended Use



WARNING

Using this equipment in ways other than described in this manual may result in personal injury, death or property and equipment damage. Use this equipment only as described in this manual.

ADB Airfield Solutions cannot be responsible for injuries or damages resulting from nonstandard, unintended applications of its equipment. This equipment is designed and intended only for the purpose described in this manual. Uses not described in this manual are considered unintended uses and may result in serious personal injury, death or property and equipment damage. Unintended uses may result from taking the following actions:

- Making changes to equipment that are not recommended or described in this manual or using parts that are not genuine ADB Airfield Solutions replacement parts.
- Failing to make sure that auxiliary equipment complies with approval-agency requirements, local codes and all applicable safety standards.
- Using materials or auxiliary equipment that are inappropriate or incompatible with ADB Airfield Solutions equipment.
- Allowing unqualified personnel to perform any task.

1.1.4 Storage



CAUTION

If equipment is to be stored prior to installation, it must be protected from the weather and kept free of condensation and dust.

Failure to follow this instruction can result in injury or equipment damage.

1.1.4.1 Operation



WARNING

- Only qualified personnel, physically capable of operating the equipment and with no impairments in their judgment or reaction times, should operate this equipment.
- Read all system component manuals before operating this equipment. A thorough understanding of system components and their operation will help you operate the system safely and efficiently.
- Before starting this equipment, check all safety interlocks, fire-detection systems, and protective devices such as panels and covers. Make sure all devices are fully functional. Do not operate the system if these devices are not working properly. Do not deactivate or bypass automatic safety interlocks or locked-out electrical disconnects or pneumatic valves.
- Protect equipment with safety devices as specified by applicable safety regulations.
- If safety devices must be removed for installation, install them immediately after the work is completed and check them for proper functioning.
- Route electrical wiring along a protected path. Make sure they will not be damaged by moving equipment.
- Never operate equipment with a known malfunction.
- Do not attempt to operate or service electrical equipment if standing water is present.
- Use this equipment only in the environments for which it is rated. Do not operate this equipment in humid, flammable, or explosive environments unless it has been rated for safe operation in these environments.
- Never touch exposed electrical connections on equipment while the power is ON.

1.1.4.2 Material Handling Precautions



CAUTION

- This equipment may contain electrostatic sensitive devices.
- Protect from electrostatic discharge.
 - Electronic modules and components should be touched only when this is unavoidable e.g. soldering, replacement.
 - Before touching any component of the cabinet you should bring your body to the same potential as the cabinet by touching a conductive grounded part of the cabinet.
 - Electronic modules or components must not be brought in contact with highly insulating materials such as plastic sheets, synthetic fiber clothing. They must be laid down on conductive surfaces.
 - The tip of the soldering iron must be grounded.
 - Electronic modules and components must be stored and transported in conductive packing.

1.1.4.3 Action in the Event of a System or Component Malfunction



WARNING

- Do not operate a system that contains malfunctioning components. If a component malfunctions, turn the system OFF immediately.
- Disconnect and lock out electrical power.
- Allow only qualified personnel to make repairs. Repair or replace the malfunctioning component according to instructions provided in its manual.

1.1.4.4 Maintenance and Repair



WARNING

- Allow only qualified personnel to perform maintenance, troubleshooting, and repair tasks.
- Only persons who are properly trained and familiar with ADB Airfield Solutions equipment are permitted to service this equipment.
 - Disconnect and lock out electrical power.
 - Always use safety devices when working on this equipment.
 - Follow the recommended maintenance procedures in the product manuals.
 - Do not service or adjust any equipment unless another person trained in first aid and CPR is present.
 - Connect all disconnected equipment ground cables and wires after servicing equipment. Ground all conductive equipment.
 - Use only approved ADB Airfield Solutions replacement parts. Using unapproved parts or making unapproved modifications to equipment may void agency approvals and create safety hazards.
 - Check interlock systems periodically to ensure their effectiveness.
 - Do not attempt to service electrical equipment if standing water is present. Use caution when servicing electrical equipment in a high-humidity environment.
 - Use tools with insulated handles when working with electrical equipment.

1.1.4.5 Operation of Overloaded Regulators



WARNING

- Operation of a Regulator while overloaded at any step may result in equipment failure or equipment damage.

2.0 BRITE III Remote

BRITE III Remotes – User Manual

General notice: other product names used here are for identification purposes only and may be trademarks of their respective companies.

AGLAS™ is a registered trademark of ADB and is known as BRITE III in the US markets.

2.1 Manual Introduction

2.1.1 How to work with the manual

2.1.2 Record of changes



- This document provides detailed information how to correctly install and maintain Bi-Directional Series Transceiver (BRITE) remotes.
 1. Be familiar with the structure and content.
 2. Carry out the actions completely and in the given sequence.

Page	Rev	Description	Checked	Approved	Date
All	4.1	New	Geert Bollens		23.12.09
	4.2	Adapted safety information	Geert Bollens		22.04.10
	C	Updated the entire manual for US market			
All	D	updated intro and install	JC	NH	8/12/11

2.1.3 Icons used in the manual

For all WARNING symbols see the Safety section.

Carefully read and observe all safety instructions in this manual, which alert you to safety hazards and conditions that may result in personal injury, death or property and equipment damage and are accompanied by the symbol shown below.

	<p>WARNING</p> <ul style="list-style-type: none"> • Failure to observe a warning may result in personal injury, death or equipment damage.
	<p>CAUTION</p> <ul style="list-style-type: none"> • Failure to observe a caution may result in equipment damage.

BRITE III Remote

2.2 BRITE Remote Introduction

2.2.1 General

The BRITE Remotes are intelligent powerline addressable field devices that operate on the secondary side of airfield isolation transformers. They serve as slave nodes in a master/slave network that is controlled by a BRITE Master. The BRITE Remote is available in the following four versions:

- BRITE Remote single channel
for controlling one light (airfield ground lighting)
- BRITE Remote dual channel
for controlling two lights (airfield ground lighting)
- BRITE Remote RGL single channel
for network-synchronized blinking after switching on, without master synchronization (Runway Guard Light)
- BRITE Remote RGL dual channel
for continuous, network-synchronized, alternating blinking of both channels after switching on, without master synchronization (Runway Guard Light)

In terms of construction, they differ in the number of channels which in turn determines the number of lights that can be switched.

RGL Remotes leave the factory with a special configuration that ensures synchronous start-up after power-up of the regulator and network-synchronized blinking without master synchronization. The factory setting also includes the choice whether the blinking is to start with "initial flash On" or "Off". This option makes it possible to have different groups of Remotes flash alternately, leveling the load on the constant current regulator caused by synchronous switching of all groups of Remotes.

In the following sections all four devices will be referred to as BRITE Remotes.

2.2.2 Illustration

Figure 1: BRITE Remote single



2.2.3 Checking the Device

2.2.3.1 Scope of Supply

The **44A6899/1100** BRITE Remote single channel is supplied with two 12-inch (30 cm) cord-set cables for connection to the series transformer and the light.

The **44A6899/1210** BRITE Remote dual channel is supplied with three 12-inch (30 cm) cord-set cables, 1 for connection to the series transformer and 2 for connection to the lights.

The **44A6899/1160 (or 1161)** BRITE Remote single channel RGL is supplied with two 12-inch (30 cm) cord-set cables for connection to the series transformer and the light, adjusted at the factory for configured start-up after switching on (consistent adjustment for all RGL Remotes in a project).

The **44A6899/1270 (or 1271)** BRITE Remote dual channel RGL is supplied with three 12-inch (30 cm) cord-set cables, 1 for connection to the series transformer and 2 for connection to the lights; adjusted at the factory for configured start-up after switching on.

See "Order Codes" on page 17" for the complete list of remote variants.

2.2.3.2 Unpacking

The device has been fully assembled, tested and packed at the factory and has no internal transport locks.

2.2.3.3 Inspection

The delivery must be checked to make sure that it is complete and in perfect condition. The supplier must be notified of any complaints within 2 weeks. After this period, complaints about the delivery will not be accepted. In the event of the goods being returned, the same transport packaging must be used. See Figure 2.

The number on the nameplate must be checked against the order number on the delivery note.

The nameplate is located on the side of the device (example: BRITE Remote single channel).

Figure 2: Nameplate of the BRITE Remote Single Channel

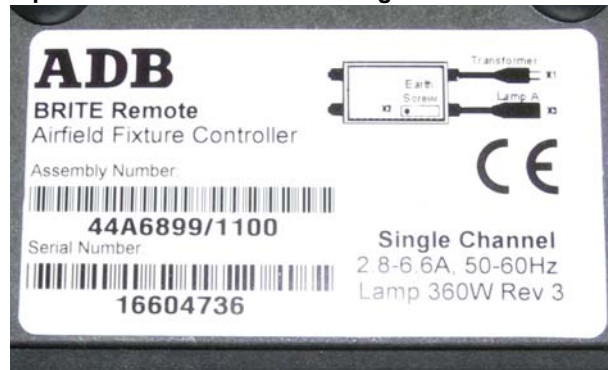

For commissioning, the serial number on the nameplate (e.g. serial number 16604736, see Figure 2) must be recorded. This is then utilized for installation and configuration.

2.2.3.4 Storage

When storing the device, it is advisable to leave it in its original packaging. The storage temperature is shown in "Technical Specifications" on page 16.

Storage Temperature: Remote: -67°F to +167°F (-55°C to +75°C)

2.2.4 View of the device with connections

Figure 3: View of the BRITE Remote Dual Channel

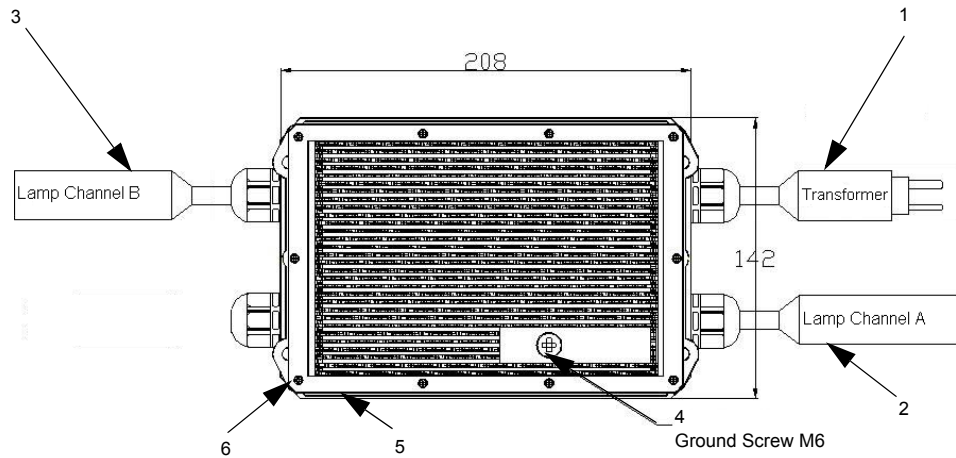

1. Cable with 2-pin plug (in compliance with FAA L-823) for connection to the series circuit isolation transformer (X3)
2. Cable with 2-pin socket (in compliance with FAA L-823) for connection to the light on channel A (X1)
3. Cable with 2-pin socket (in compliance with FAA L-823) for connection to the light on channel B (for dual Remote only) (X4)
4. Ground cable connection (X2)
5. BRITE Remote housing
6. Holes for the mechanical attachment of the BRITE Remote (e.g. via cable ties)

NOTE: See nameplate of BRITE Remote (Figure 2) for identification of connections marked "X".

2.2.5 Construction

The BRITE Remote is sealed to make it watertight and gas-tight and must not be opened.

NOTE: Once the Remote has been opened, the warranty is void.
A defective or open Remote must be returned to the manufacturer.

2.2.5.1 Block diagram

Figure 4: Block diagram of the BRITE Remote dual

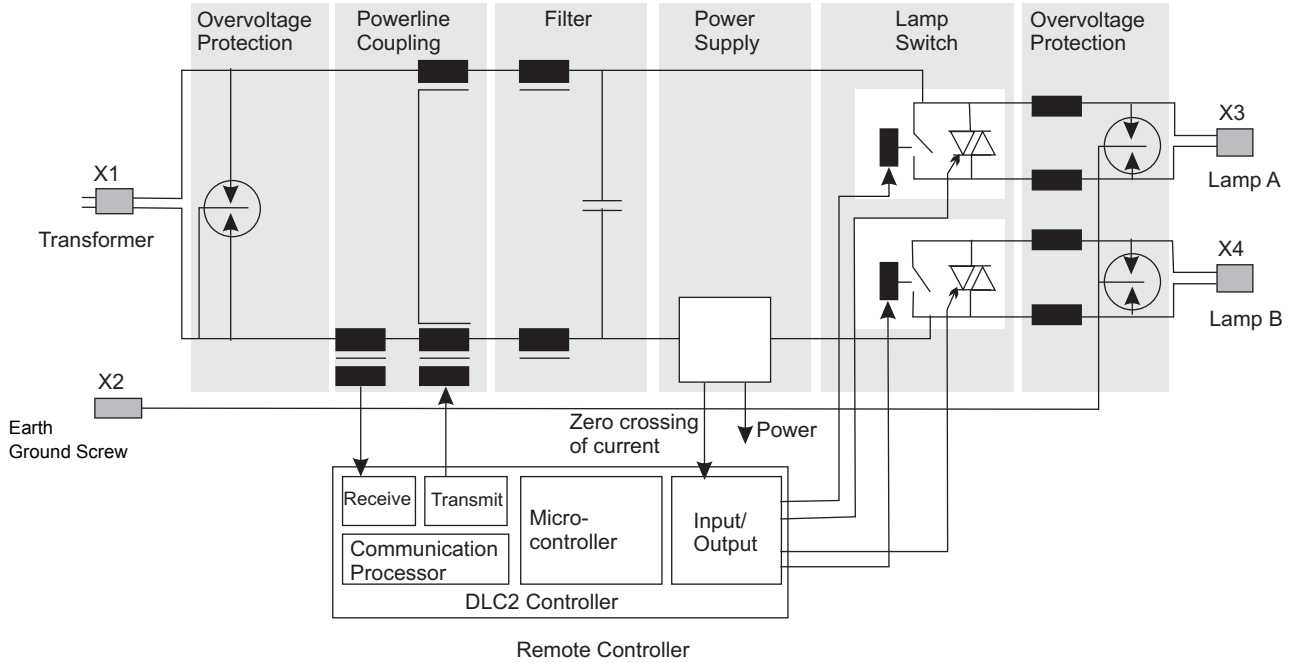

BRITE Remote
Introduction

2.2.6 Theory of Operation

Background Information: BRITE uses power line carrier technology to communicate between controlling units on an airfield lighting series circuit. A BRITE system typically consists of one high voltage modem, or Master, connected with the Constant Current Regulator (CCR) powering the airfield lighting circuit and many slave units, or Remotes, collocated with individual lights in the field. A typical BRITE topology is provided in Figure 5.

Figure 5: Typical BRITE Topology

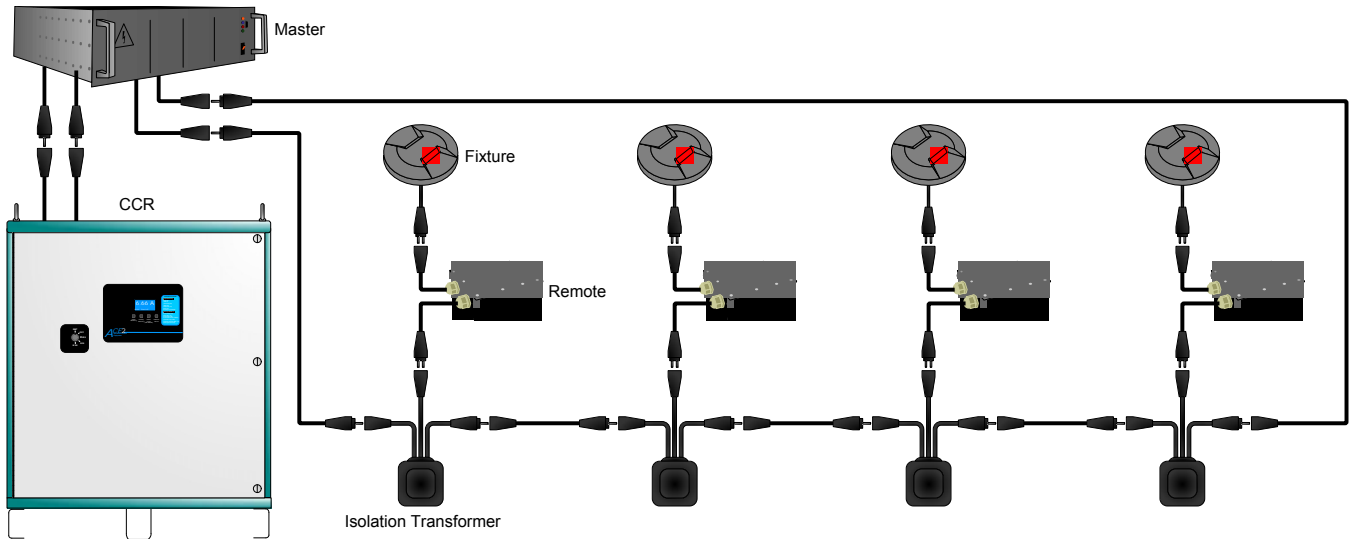

BRITE Remote Introduction

2.2.6.1 Architecture

Figure 6 depicts the general nature of the system components and their interactions. The "Control System", shown in grey, is an external ALCMS system that provides controlling commands and digests Master and Fixture status reports. There is typically only one control system in the architecture. The "Master", shown in blue, is the high voltage modem that communicates commands to and receives status from the fixtures. There can be many masters in a given system. Masters digest commands from the control system and provide status to it. Masters also communicate amongst themselves to maintain communication timing synchronization. Each master communicates with the fixtures on its respective circuit.

Figure 6: Series Circuit Master / Fixture Architecture

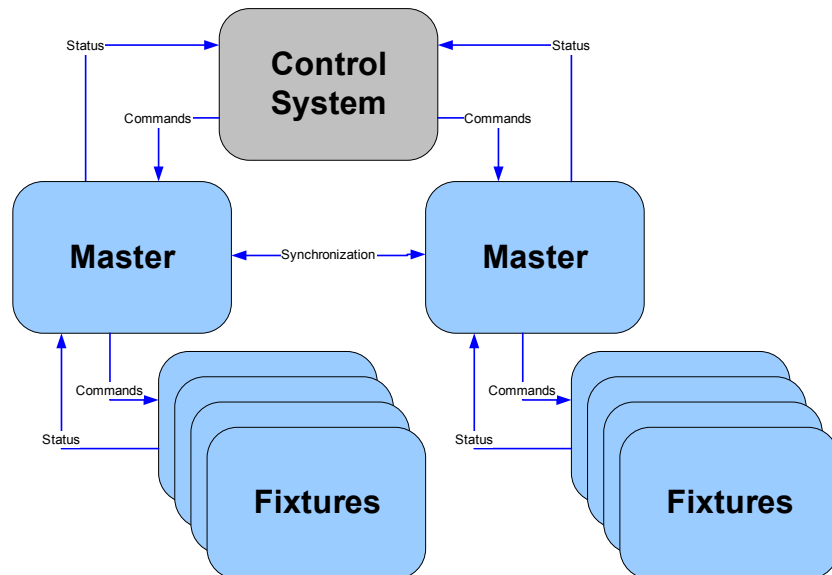

2.3 Installation

Installation is identical for all BRITE Remote versions.

Figure 7: Diagram of BRITE installation in series circuit

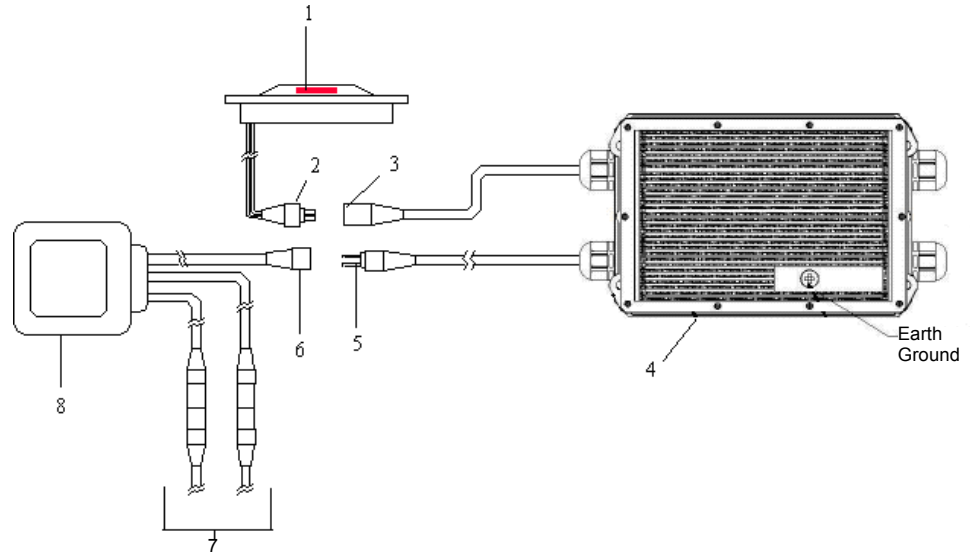

- | | |
|------------------------------------|--------------------------------------|
| 1. Light Fixture | 5. Remote Input Plug (TRANSFORMER) |
| 2. Light Fixture Plug | 6. Transformer Secondary Receptacle |
| 3. Remote Output Receptacle (LAMP) | 7. Primary Series Circuit |
| 4. Remote | 8. L-830/L-831 Isolation Transformer |

2.3.1 Installation in a Transformer Pit

The orientation required for installation is indicated by the labelling on the nameplate. This ensures optimum heat dissipation through the housing. If the device is installed by suspension, free air circulation must be provided through the cooling fins of the BRITE Remote.

NOTE: If several BRITE Remotes are installed in a single pit, they should be spaced with a distance of at least 2-inch (50mm) from each other and from the series transformers to have optimum communication signal separation. Because the communication signal is coupled magnetically, the distance between the transformers should also not be less than 2-inch (50mm).

Minimum distance between remote cable feed-throughs and pit walls is 2-inch (50 mm).

Figure 8: Remote max. bending radius

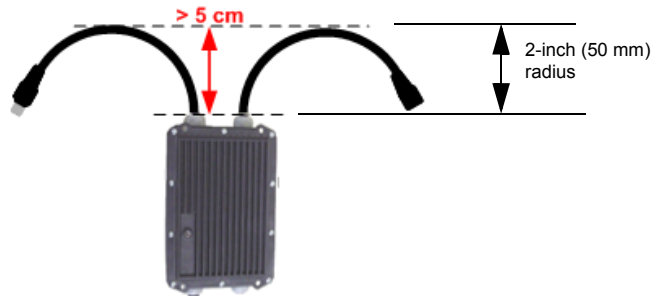

2.3.2 Connection to the Series Transformer and the Light Fitting(s)

The 2-pin plug on cable X1 is connected to the socket for the secondary circuit of the series transformer. The light(s) is/are connected to the 2-pin socket(s) of the cable(s) X3 (and X4 for the dual BRITE Remote).

All plug connections must be sealed with self-bonding insulation tape or using “heat shrink” sleeves.

To improve watertightness, an optional watertight heat shrink sleeve can be installed at the junction of the plug and receptacle: (see Figure 9)

Figure 9: Connection to series transformer and light fitting

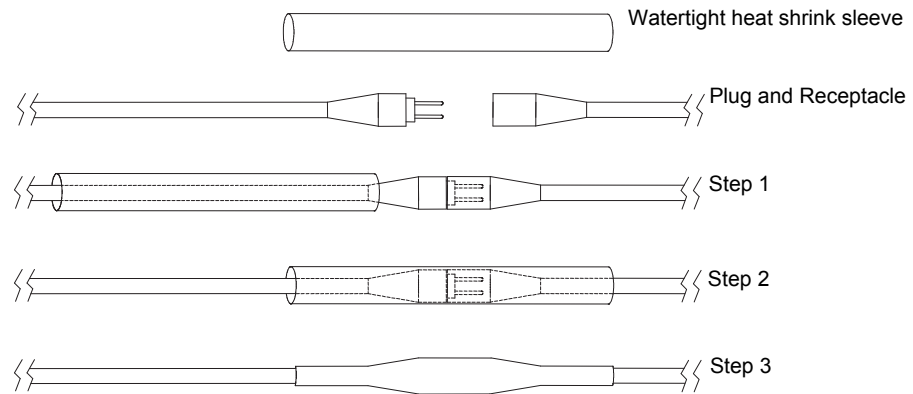

Step 1:

Place the heat shrink sleeve over the light inset plug wire.

Step 2:

Connect the inset light plug to the Remote receptacle designated CHANNEL A (and CHANNEL B if used).

Step 3:

Pull the heat shrink sleeve over the plug-to-receptacle connection. Heats shrink the sleeve.

Repeat steps 1 through 3 for the Remote plug designated TRANSFORMER and the transformer secondary receptacle.

2.3.3 Earth Grounding

To protect it against a surge generated by lightning, each BRITE Remote should be provided with a separate, low induction and low resistance ground connection via the ground screw. The ground cable must be connected to the ground screw by means of a suitable cable lug. The cross-sectional area of the cable should be at least AWG 8 (6 mm²) with a maximum cable length of 36-inch (1m).

If the isolation value of the earth ground is bad, it is better NOT to connect the remote to earth ground (see Figure 10).

Figure 10: Connection to a series circuit isolation transformer and light fitting

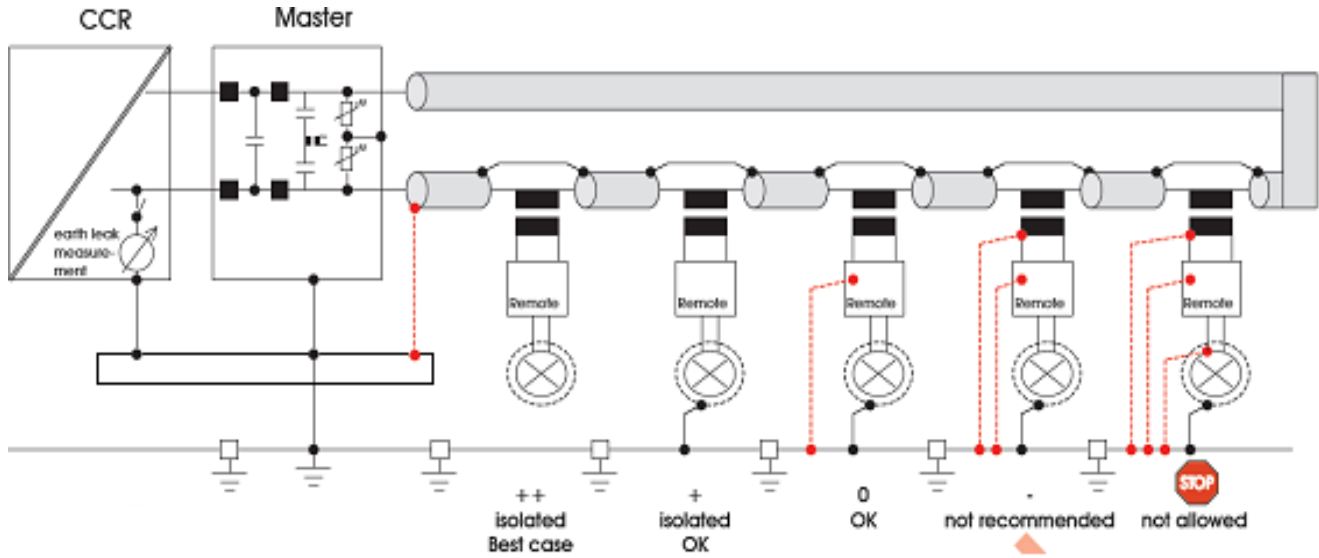

2.3.4 Safety Instructions



DANGER

Work on 120/240 V power supply systems or the series circuit must only be carried out by trained, qualified staff.
The currently applicable regulations according to international standards must be followed.
See also “Safety” on page 1

NOTE: The BRITE Remote is maintenance free.
The BRITE Remote must never be opened, otherwise warranty will be void.

2.3.5 Replacing a BRITE Remote

- Step 1:**
In each case, inspect the technical condition of the BRITE Remote which has to be removed or replaced, or the BRITE Remote which is to be installed as a replacement device.
- Step 2:**
If the old remote is still communicating with the master (can be verified with the BRITE Configuration software), it is recommended to logout this remote prior to removal.
Follow the “Logout procedure” procedure as described in “96A0430 BRITE Configuration Software - User Manual”.
If the remote is completely dead, Step 2 is not applicable.
- Step 3:**
Switch off and disconnect the associated series circuit from the incoming power by removing the fuses of the Constant Current Regulator (CCR).
- Step 4:**
Pull out the cut-out for the series circuit, if possible ground the series circuit and wait about 5 minutes until the circuit is fully discharged.
- Step 5:**
Removing a BRITE Remote: first, separate the series circuit connections X3 and X1 and, in the case of the dual BRITE Remote, X4 at the cable plug connections. Then, open the ground connection X2 by unscrewing the earth ground screw.

Installation

Step 6:

Installing a BRITE Remote: install the new BRITE Remote according to the “Installation” on page 9.

Step 7:

Switch on the associated series circuit and verify if the replaced remote connected lamp(s) are functioning (for RGL remotes: blinking).

Step 8:

Follow the “change remote” procedure as described in “96A0430 BRITE Configuration Software - User Manual” to make the replaced remote operational.

2.4 Modes of Operation of a BRITE Remote

2.4.1 Frequency Scan

Initial State on a new remote from the factory.

State on delivery

On delivery, each new BRITE Remote that has not yet been logged on with a BRITE Master is in "frequency scan mode". For power-up mode ("On"), fail-safe mode ("On") and Delayed Start/Stop ("Off") it uses the factory settings, which are given here in brackets (default values). RGL/Wig-wag remotes are pre-configured with "Blink" for power-up and fail-safe mode.

Base state

A BRITE Remote that has been logged off from a circuit also reverts to frequency scan mode. However, for power-up mode, fail-safe mode and Delayed Start/Stop it uses the most recent settings received from the BRITE Master (most recent configuration). In frequency scan mode, a BRITE Remote, when it is installed in a series circuit and the latter is turned on, searches on all frequency bands for a master telegram containing its serial number. If this search is successful, the BRITE Remote logs on to the corresponding BRITE Master. When an BRITE Remote is logged off from a circuit, it reverts to base state.

2.4.2 Operating Mode

After successfully logging on, a BRITE Remote automatically switches to "operating mode" (normal operation) and receives its configuration parameters from the BRITE Master. All parameters are stored firmly in the BRITE Remote. In operating mode, all lights connected to the BRITE Remotes can be switched independently of each other via single or block commands (i.e. a command switches a predefined group of lights). The switch commands can be "On", "Off" or "Blink".

When a BRITE Remote receives a switch command it returns the message "switch command executed" (block command) or "switch command received" (single command). However, the real status of the lights is only determined at the next status polling by the BRITE Master. In the BRITE Remote, each switching operation for the light is carried out first via an electronic switch and then via a relay ("blink" mode is established with electronic switch only).

Each BRITE Remote monitors the status of the lights connected to it (maximum of two lights). The monitoring takes place when the light is switched on by default. Whether the lamp should be monitored in the "Off" state too, is configurable. Once a lamp failure has been detected ("Open"), the light is no longer monitored during this operation period and switch commands for this light are ignored. It will not be checked again until the circuit has been switched off and on again or after the reception of a reset command (software function) from the BRITE PC.

2.4.2.1 Self-test Mode

After the series circuit has been switched on, each BRITE Remote runs a self-test. If an error is detected through this test, the BRITE Remote switches to error mode. This means that communication with a BRITE Master is not possible.

During normal operation, the remote also checks the switching and high voltage protection devices. If any problem should occur with these devices (after 9 lightning strike for example), a specific error message is sent to the master.

2.4.3 Switch Status of the Connected Lights

One light can be connected to each single channel BRITE Remote, and up to two lights (“A” and “B”) can be connected to each dual channel BRITE Remote. A light can assume the following types of status:

- “Off” (light is switched off and not burning).
- “On” (light is switched on and the electric circuit is closed).
- “Open” (light is switched on but the electric circuit is not closed, i.e. the light filament is broken or the light is not connected).
- “Blink” (light flashing; no information as to whether the light is “On” or “Off” at the time of polling).

On the Graphical User Interface (GUI), the status of each light is indicated by the terms given in quotation marks.

2.4.4 Switch Status under Special Circumstances

With the help of the BRITE PC software, the user has to configure each BRITE Remote of a circuit to which the Remote shall switch its connected lights:

- When the series circuit is powered up (power-up mode),
- When the communication between the BRITE PC and the BRITE Master or between the BRITE Master and the BRITE Remote is interrupted (fail-safe mode),
- And if there is to be a Delayed Start/Stop or not (when several lights are switched simultaneously by a block command).

2.4.4.1 Power-up Mode

The “power-up mode” defines to which status the BRITE Remotes should switch their lights directly after power-up of the series circuit. The parameters of the following types of switch status can be set via the BRITE PC:

- “On”.
- “Off”.
- “Blink” (flashing).
- “Last Commanded State” (maintain the last operating status).

This mode ends after a switch command from the BRITE Master has been received.

2.4.4.2 Fail-safe Mode

As soon as the BRITE Remote detects a failure of the communication with its BRITE Master or receives a failsafe telegram from it, it switches the connected light(s) into a predefined status. This status can be parameterized via the BRITE PC software as follows:

- “On”.
- “Off”.
- “Blink” (flashing).
- “Last Commanded State” (maintain the last operating status).

The duration of the interval before a communication problem is identified can be configured via the BRITE PC software as well. The failsafe mode is not exited automatically after communication has been restored but only after the BRITE Remote has received a switch command from the BRITE Master.

2.4.4.3 Delayed Start/Stop

When switching several lights via a block command, the lights can be controlled using a defined delay (ms), which can be configured. This setting ensures constant current regulator stability in case of large load fluctuations. The following parameters can be set:

- No delayed switching.
- Delayed switch-on/off setting 1 (10ms delay per lamp)
- Delayed switch-on/off setting 2 (20ms delay per lamp)
- Delayed switch-on/off setting 3 (30ms delay per lamp)
- Delayed switch-on/off setting 4 (40ms delay per lamp)
- Delayed switch-on/off setting 5 (50ms delay per lamp)

2.4.5 Spreadsheet

It is recommended to maintain a list of installed remotes during installation, containing the BRITE remote serial number and the fixture number. This table will later on be used to build the ALCMS database. See Figure 11.

Figure 11: Spreadsheet Example

AGLAS circuit and Remote information sheet for the installer							
Circuit information						Totals (calculated)	
Substation Name:	26L-					Single remotes:	2
Circuit Name:	TC1-					Dual remotes:	0
Circuit Length (approx.):	5						
Number of light fixtures:	105						
Number of remotes:	105						
Remote information (* = required)				Channel A		Channel B (only if dual remote)	
Remote Name	Serial number *	Pit Name/Nr	Transfo Type	Light Reference *	Light Fix. Type	Light Reference *	Light Fix. Type
26L-TC1-A7-TC1-7	900101	A7-	RST-100W	TC1-7	FTS-2-045-GG		
26L-TC1-A7-TC1-9	900102	A7-	RST-100W	TC1-9	FTS-2-045-GG		

Modes of Operation of a BRITE Remote

2.4.5.1 A sample spreadsheet would contain:

- Vault/substation name: the official name of the vault/substation were the circuit is powered.
 - Circuit name: the local name of the circuit (like TC3).
 - Circuit length: the approximate length of the circuit (in kilometres).
 - Total number of light fixtures: for reference only (not required).
 - Number of remotes: the total number of BRITE remotes on this circuit.
 - Remote name: is automatically generated, but may be altered to serve your own needs. Max. 50 characters are allowed. Remember that this will be your only lead to identify and locate lights and remotes out of the BRITE system.
 - Serial number: is unique for every BRITE remote and is required to fill-in.
 - Pit Name/Nr: for your own reference only.
 - Transfo type: (transformer type) only for your reference.
 - Light reference: unique identifier for the connected light fixture on the airfield (see AutoCAD drawing).
 - Light Fixture Type: for your own reference only.
 - If the remote is a Dual type: reference must be filled in for Channel B also, even if the light fixture is the same as for Channel A (one fixture with 2 lamps).
- Underlined information is mandatory and the absolute minimum required data.

2.5 Technical Specifications

Table 1: Technical Specifications BRITE Remote

Parameter	Values	
	BRITE Remote single	BRITE Remote dual
Operating temperature	-40°C to +65°C	
Storage Temperature	-40°C to +75°C	
Max. operating humidity	100%	
8 different frequency bands between	20kHz and 150 kHz	
Maximum switching power	360W	$P_{ChA} + P_{ChB} \leq 360W$
Power consumption	<22 VA	
Minimum operating current	1.9A RMS	
Maximum operating current	6.9A RMS	
Maximum circuit peak current	40A	
Protection class	IP 687 Remote: IP 68 (NEMA 6P)	
EMC (CE certified)	complies with EN 50081-2 (EMC emission standard) complies with EN 61090-6-2 (EMC immunity standard) complies with EN 60950 (IT equipment standard)	
Overvoltage protection	BRITE is lightning protected according to the specification in FAA AC 150/5345-47: 10/20 μ s current surge of 15kA with subsequent operating current and a voltage surge of 10kV/ μ s	
MTTR (mean time to repair)	< 30 minutes	
MTBF (mean time between failures)	> 100,000h at ambient temperature of 40°C	
Number of lights controlled and monitored	1	2
Power-on time	< 1s	
Lamp fault detection	Lamp is short-circuited when a filament break is detected	
Data retention after power failure	The Remote does not have to re-start if the power failure is less than 1.5s	
Data transmission rate power line:	Remote: Up to 40 kB/s	
Maximum roundtrip series circuit length:	Up to 9.3 miles (15Km)	
Dimensions (W x D x H)	8.11 x 5.47 x 3.07 in (206 x 139 x 78 mm)	
Weight	3.97 lbs (1.8 kg)	4.2 lbs (1.9 kg)

2.5.1 Order Codes

Table 2: Order Codes

Ordering Code

BRITE III Master **44A6898**

For use on up to 30KW CCR, 19-inch Rack Mount

BRITE III Remote **44A6899-XXXX**

Configuration

- 1100 = Single Channel, no Runway Guard Light
- 1160 = Single Channel with RGL, Initial Flash ON
- 1161 = Single Channel with RGL, Initial Flash OFF
- 1210 = Dual Channel, no Runway Guard Light
- 1270 = Dual Channel with RGL, Initial Flash ON
- 1271 = Dual Channel with RGL, Initial Flash OFF

Technical Specifications

**BRITE III Remote Control Device
Installation Manual**

Registered office:

ADB Airfield Solutions LLC
977 Gahanna Parkway
Columbus, OH 43230
USA
Phone: +1 (614) 8611 304
Fax: +1 (614) 8642 069

France
Phone: +33 (1) 4922 9250
Fax: +33 (1) 4922 9255

ADB Airfield Solutions GmbH & Co. KG
Von-der-Tannstr. 31
90439 Nürnberg
Germany
Phone: +49 (911) 9239 1287
Fax: +49 (911) 2852 582

ADB
Unit 44, Business Innovation Centre
Binley Business Park
Harry Weston Road
Coventry, CV3 2TX
United Kingdom
Phone: +44 (0)1455 883130
Fax: +44 (0)1455 883179

Other addresses:

ADB Airfield Solutions Ltd.
5500 North Service Road, Suite 1108
Burlington, Ontario L7L 6W6
Canada
Phone: +1 (905) 331 6887
Fax: +1 (905) 331 9389

ADB N.V.
Asia Pacific Regional HQ
Unit C-9.3.1, Level 9, Block C
Mines Waterfront Business Park
No. 3, Jalan Tasik
The Mines Resort City
43300 Seri Kembangan Selangor
Malaysia
Phone: +603 8941 4868
Fax: +603 8942 4869

ADB
Airfield Solutions
Leuvensesteenweg 585
B-1930 Zaventem
Belgium
Phone: +32 (2) 722 17 11
Fax: +32 (2) 722 17 64
info.adb@adb-air.com
www.adb-air.com

ADB Airfield Technologies Ltd.
01A Unit, 9F, LSH Plaza
8, Wangjing Jie
Chaoyang District
Beijing 100102
P.R. China
Phone: +86 10 8476 0106
Fax: +86 10 8476 0090

ADB Airfield Solutions Netherlands
Prinses Beatrixlaan 614
Office D3.14
2595 BM Den Haag
The Netherlands
Phone: +31 (0)70 304 3611
Fax: +31 (0)70 333 8094

ADB N.V.
Dubai Silicon Oasis
Wing D - Office D-309
P.O. Box 341218
United Arab Emirates
Phone: + 971 4372 4970
Fax: + 971 4372 4975

ADB Airfield Solutions, Ltd.
2nd Floor, 3 Rivonia Village
Cnr Mutual Road and Rivonia Boulevard
South
Rivonia 2128
South Africa
Phone: +27 (11)234 6768
Fax: +27 (11)234 6739

ADB N.V./S.A.
39/47 Boulevard Ornano
93200 Saint-Denis

**ADB Airfield
Solutions USA**

977 Gahanna Pkwy
Columbus, Ohio 43230 USA
Telephone: (+1 614-861-1304)
Fax: +1 614-864-2069
www.adb-airfieldsolutions.com

The information contained in this document is subject to change without notice. ADB reserves the right to make changes and improvements to its products and assumes no responsibility for making these modifications on any equipment previously sold.

96A0429 © 2010 ADB Airfield Solutions All Rights Reserved

Document Date (12/2010)